

4.3-inch Color LCD GPS Navigator **KGP-922**



Features

- ▶ Meeting with IMO requirements and IEC regulations
- ▶ Eye-friendly 4.3-inch high-resolution Color LCD
- ▶ Numeric keypad mounted
- ▶ DGPS enabled by connecting an external beacon receiver (owner supplied)
- ▶ SBAS (Satellite Based Augmentation System) enabled
- ▶ 5,000 waypoints, 100 routes and 3,000 track points
- ▶ Ethernet port for connection to a LAN
- ▶ Equipped with two data port of NMEA0183

< Screen Image >

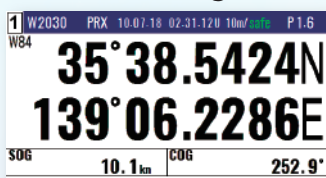

Nav Data

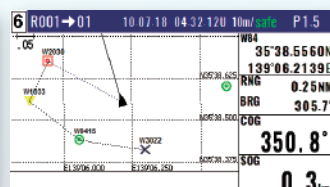

Plotter

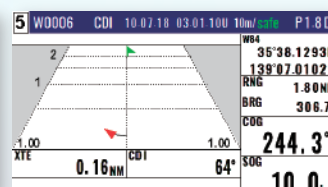

Highway

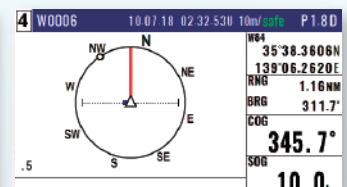

Navigation Graph

SPECIFICATIONS

Model	KGP-922
Receiving frequency	1575.42 MHz±1MHz
Receiving channel	72 channel parallel
Receiving code	C/A code
Sensitivity	Better than -148 dBm
Accuracy	Position SOG COG
HDOP≤4	4.2 m 2drms(GPS), 3.3 m 2drms(DGPS) 0.1 kt rms ± 1.0°
Display size and type	4.3inch color LCD
Display resolution	480 x 272 (WQVGA)
Display mode	NAV1, NAV2, NAV3, NAV4, NAV5, NAV6, NAV7, MOB (Man Over Board)
Track display	Display range Usable ground Plotting interval Plotting capacity
Position data display	Latitude / Longitude in increments of 0.0001 minute, Converted Loran C LOPs, Converted Loran A LOPs, Converted Decca LOPs
Navigational display	Speed, Course, Distance / Bearing to waypoint, Cross track error, Time to go to waypoint, Total time to go and distance on route, DOP value, Present time (UTC or L.TC), Satellite status, Beacon receiving status, Distance / Bearing between two points, MOB display
Instant (event) memory	1,000 points
Waypoint memory	5,000 points (4,000 + Event 1,000)
Route memory	100 routes reverse trail possible
Alarms	Proximity, Cross track error, CDI, Anchor watch
Position compensation	Latitude / Longitude, LOPs, Datum
Magnetic compensation	Auto or Manual
Parameters	Position(L / L LOP), Memory of waypoints and name (up to 10 letters), Selection of measuring unit (nm, sm, km), SOG,COG averaging (smooth) factor, Sailing mode (Great Circle, Rhumb Line), DGPS mode, Beacon stations selection
Output data format and sentences	NMEA 0183 Ver.2.0 / 3.0 / 4.1 CIF (AAM, APB, BOD, BWC, DCN, DTM, GGA, GLC, GLL, GSA, GSV, MSS, RMB, RMC, RTE, VTG, WPL, XTE, ZDA)
Input data format	RTCM SC104 Ver.2.0 (DGPS), NMEA 0183 (GPS source: External)
NMEA ports	Total 2 : input and output
Power supply	10.8 to 31.2 V DC
Power consumption	6 W or less (24V DC)

Note: Accuracy is subject to change in accordance with DoD civil GNSS user policy.

Environmental

Operating temperature	Display unit: -15 °C to +55 °C Antenna unit: -25 °C to +55 °C
Water protection	Display unit: IPX2 Antenna unit: IPX6

CONNECTIONS

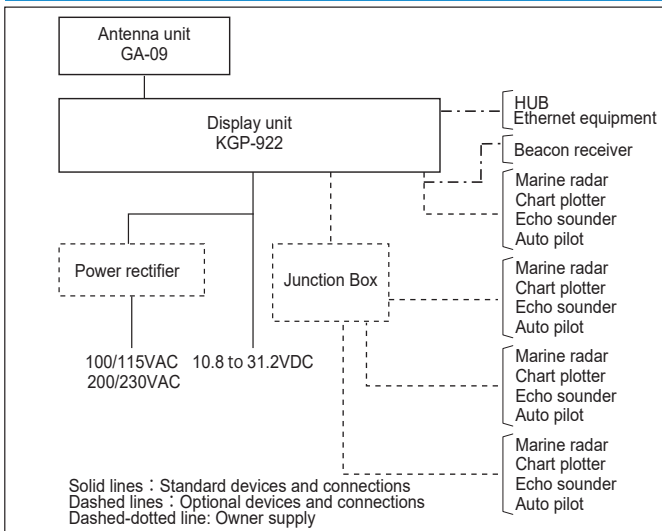

EQUIPMENT LIST

Standard Equipment

Display unit	KGP-922	With mounting bracket and front cover
Antenna unit	GA-09[15M]	With 15m antenna cable and BNC connector
	GA-09[0.5M]	With 0.5m antenna cable and N-P connector
DC power cable	CW-276-2M	With 5-pin connector and one end plain (2m)
Operation Manual, Installation material		

Options

Antenna holder, Connecting cable, Junction box, Hose band, Power rectifier, AC power cable, Antenna cable extension kit, Conversion cable

DIMENSIONS AND WEIGHT

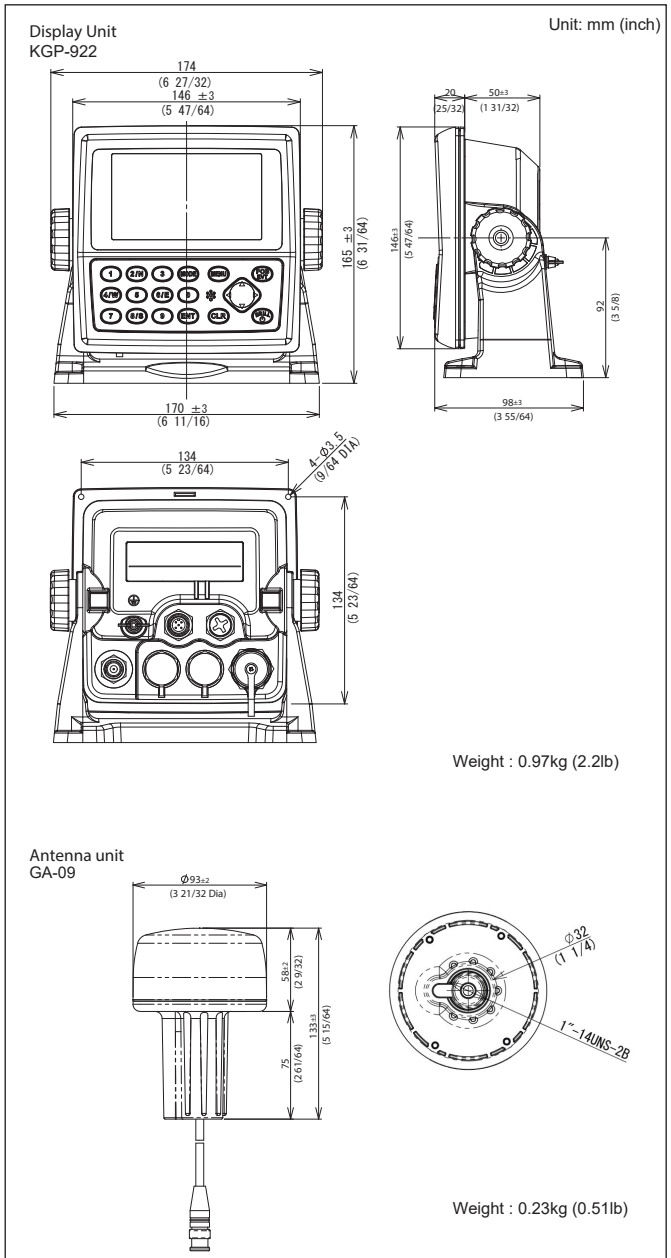

• Design and specifications are subject to change without notice.

KODEN Kodens Electronics Co., Ltd.

Tamagawa Office:
2-13-24 Tamagawa, Ota-ku, Tokyo, 146-0095 Japan
Tel: +81-3-3756-6501 Fax: +81-3-3756-6509
Uenohara Office:
5278 Uenohara, Uenohara-shi, Yamanashi, 409-0112 Japan
Tel: +81-554-20-5860 Fax: +81-554-20-5875

overseas@koden-electronics.co.jp

www.koden-electronics.co.jp



Safety precaution

To ensure proper and safe use of the equipment, please carefully read and follow the instructions in the Operation Manual.

For details, please contact: