

Front view
正面図

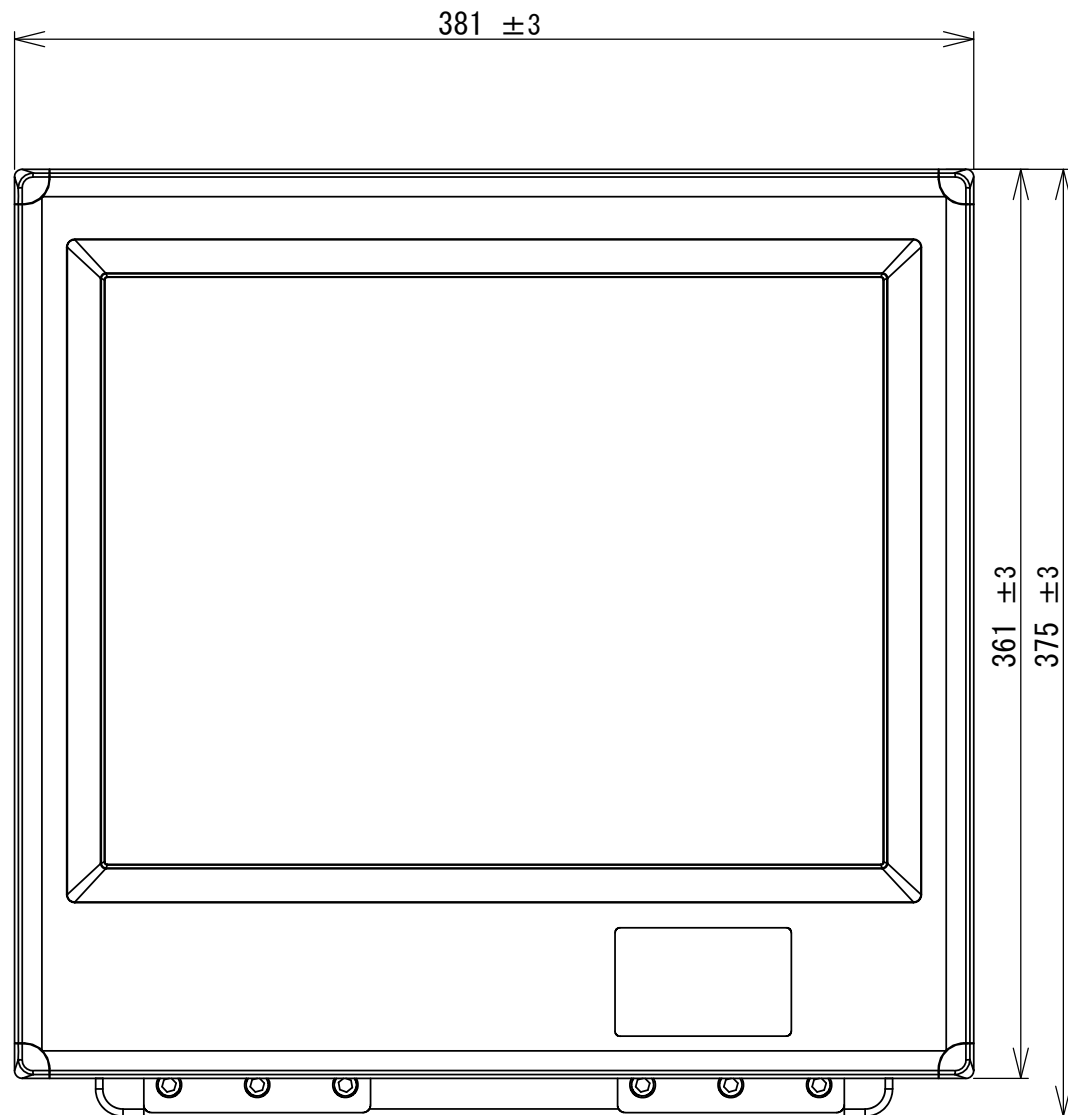

Side view
側面図

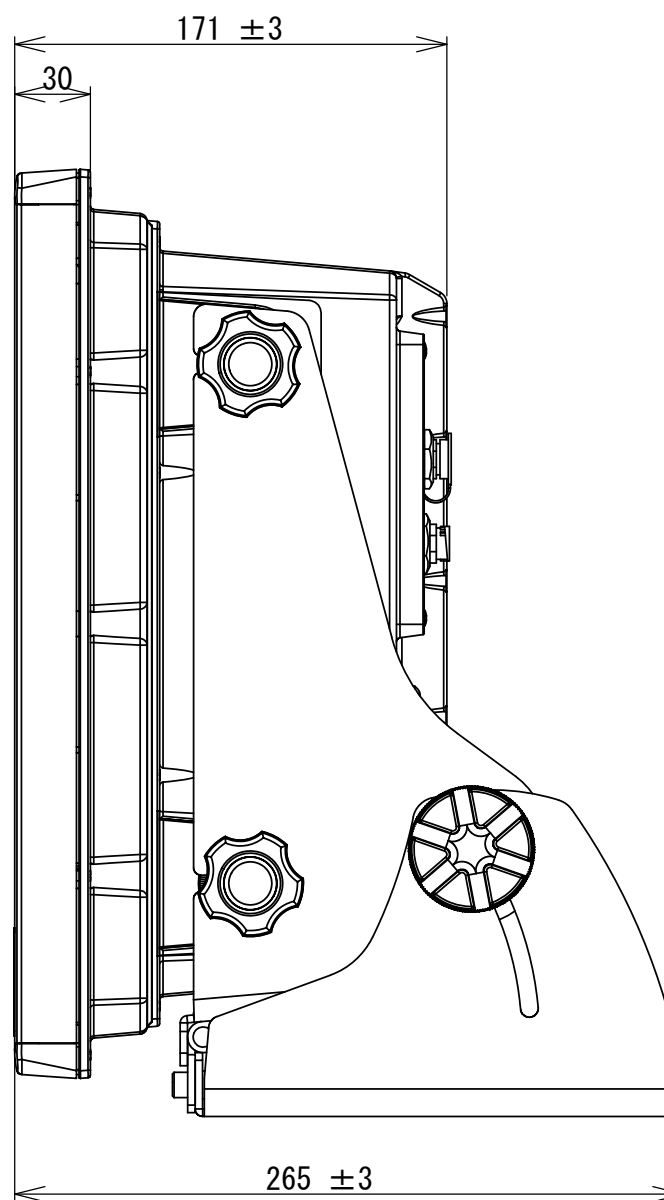

Rear view
背面図

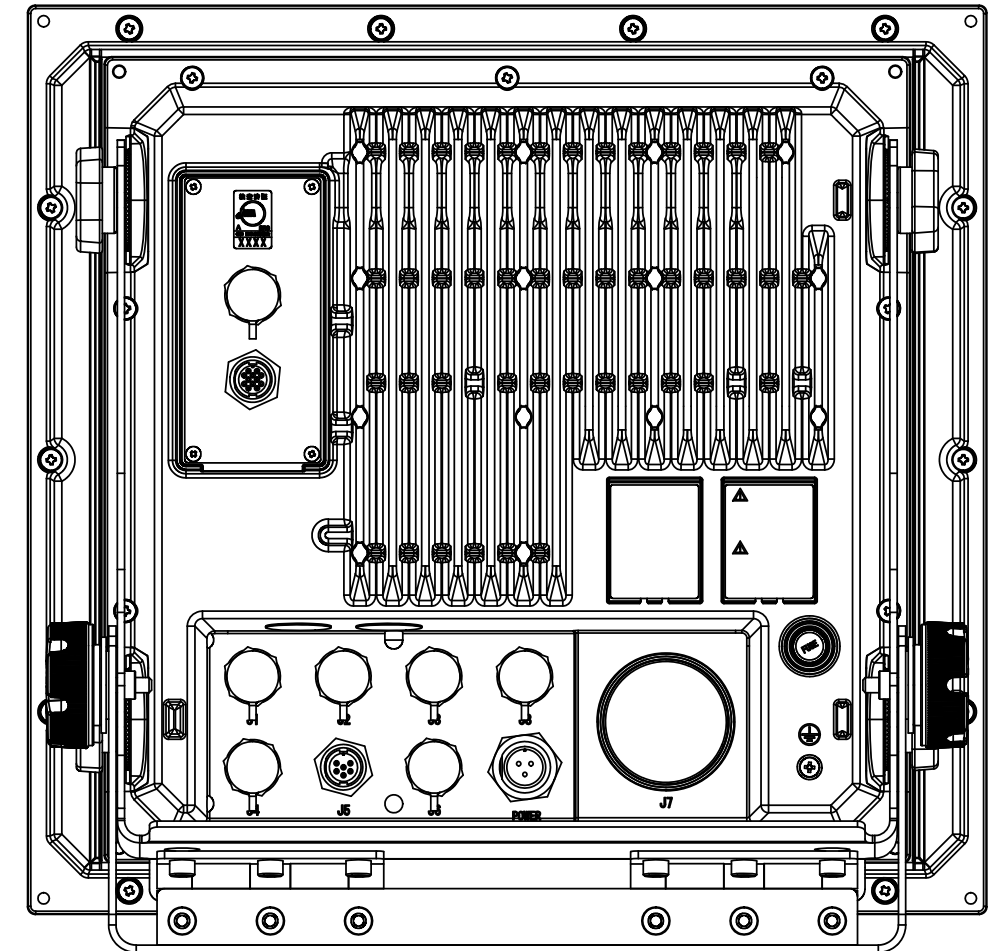

Weight: 12kg [inclusive base / 架台含む]
重量

						APPROVED Sep. 24.2013 <i>J. Hiramoto</i>	CHECKED Sep. 24.2013 <i>M. Soguma</i>	DRAWN Sep. 20.2013 <i>M. Ozaki</i>	TYPE CPD-100 (GTD-161)	TITLE Outline & dimensions of display unit 表示機外観寸法図
SYM.	DESCRIPTION OF REVISIONS	DATE	DRAWN	CHD.	APPD.	UNIT mm / (inch)	SCALE 1 : 3	KODEN Kodon Electronics Co.,Ltd.		DWG.No. D87BG11000

Plan view
平面図

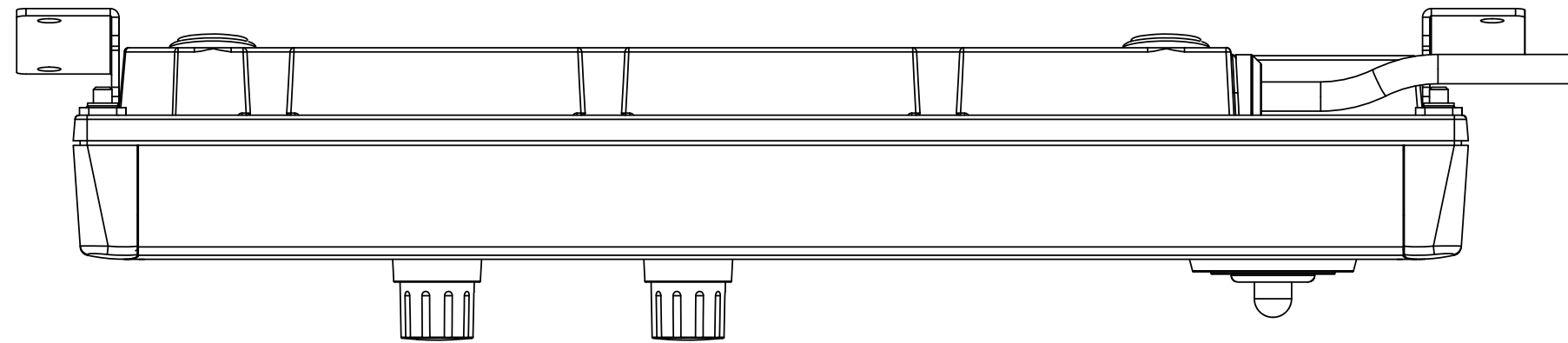

Side view
側面図

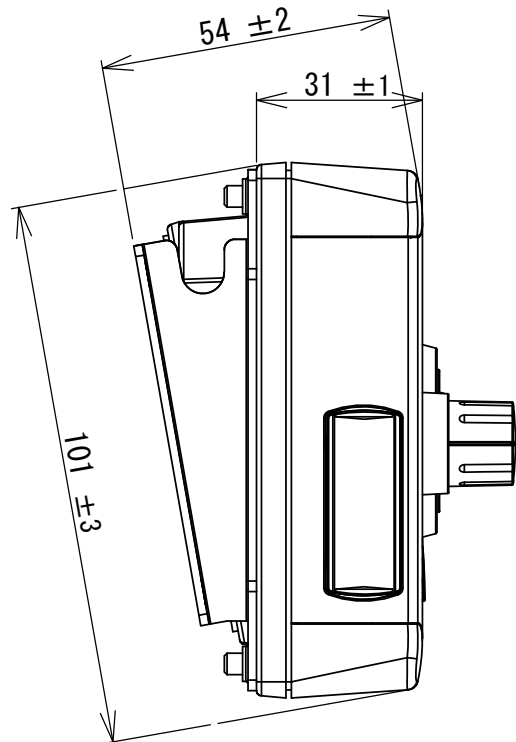

Front view
正面図

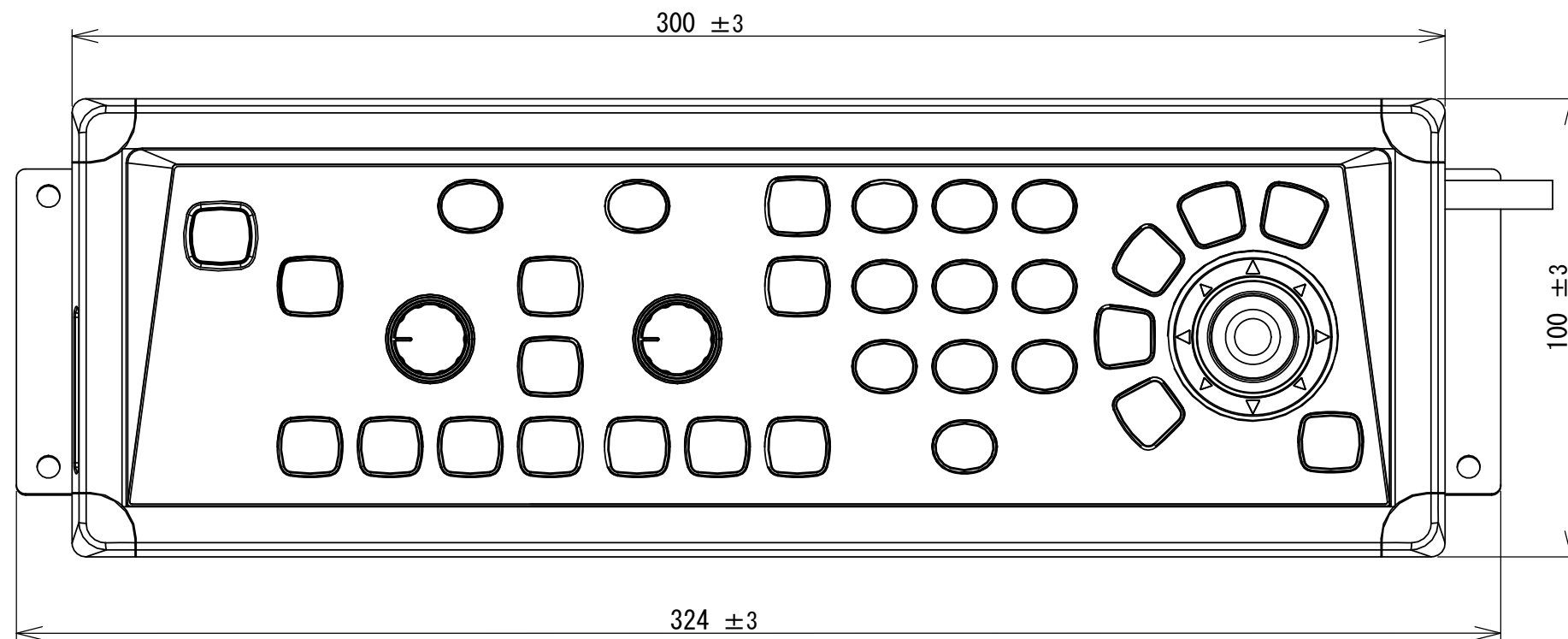

Weight: 1.1kg [inclusive base and 5M connecting cable
重量 / 架台及び5M 接続ケーブル含む]

						APPROVED Sep. 24. 2013 <i>J. Hiramoto</i>	CHECKED Sep. 24. 2013 <i>sc. saizumi</i>	DRAWN Sep. 24. 2013 <i>M. Ozaki</i>	TYPE CPO-100 (GTD-161)	TITLE Outline & dimensions of operation unit 操作部外観寸法図
SYM.	DESCRIPTION OF REVISIONS	DATE	DRAWN	CHD.	APPD.	UNIT mm / (inch)	KODEN Kodon Electronics Co.,Ltd.			DWG.No. D87BG21000
						SCALE 1:√2				