

KODEN

INSTALLATION MANUAL

GPS RECEIVER MODULE

GPS-20A MkII

This product is specifically designed to be installed on boats and other means of maritime transport. If your country forms part to the EU, please contact your dealer for advice before attempting to install elsewhere.

GPS-20A MkII Installation Manual**Doc No: 0092621642****Document Revision History**

No.	Doc. No-Rev. No.	Date revised (Y/M/D)	Revised content
0	0092621642-00	2018/12/27	First edition
1			
2			
3			
4			
5			
6			
7			
8			
9			
10			

Document No. Revised Version Norm

When part of the document needs to be revised, the document has advanced revision number.

The document No. is indicated at the lower right side on the cover and at the left or right side of the footer region of each page.

© 2018 Kodan Electronics Co., Ltd. All rights reserved.

No part of this publication may be reproduced, transmitted, translated in any form by any means without the written permission of Kodan Electronics Co., Ltd. The technical descriptions contained in this publication are subject to change without notice. Kodan assumes no responsibility for any errors, incidentals or consequential damages caused by misinterpretation of the descriptions contained in this publication.





Important Notice

- For copy and transcription of this Installation Manual (hereinafter referred to as this manual), permission from Koden is needed. Koden prohibits the un-authorized copy and transcription of this manual.
- If this manual is lost or damaged, consult a dealer of Koden or Koden.
- The specification of the products and the contents in this manual are subject to change without notice.
- The contents displayed on the menu of product may be different from the expression of this manual. The fonts and shapes of the keys and menus in the illustration may differ from the actual ones, and some parts may be omitted.
- Koden is not liable for damages and troubles arisen from misunderstanding of the contents in this manual.
- Koden is not liable for any damages caused by earthquake, lightning, wind and flood damage and fire for which Koden is not responsible, and actions by third parties, other accidents, customer's unintended error/abuse and the use under other abnormal conditions.
- Koden is not liable for damages of accompaniment (change/loss of memorized content, loss of business profit, stop of business) arisen from use or failure of our products.
- If the stored data are changed or lost, irrespective of causes of troubles and damages, Koden is not liable for them.
- Koden is not liable for any damages arisen from malfunction caused by combination of software and connected equipment in which Koden is not engaged.





For Your Safe Operation

Symbol used in this Installation Manual

The following pictograms are used in this manual. The meaning of each symbols shall be well understood and the maintenance and inspection shall be carried out.





Symbol	Meaning
 Warning	Mark for warning This mark denotes that there is a risk of death or serious injury when dealt with incorrectly.
	Mark for danger of high voltage This mark denotes that there is a risk of death or serious injury due to electric shock when dealt with incorrectly.
 Caution	Mark for caution This mark denotes that there is a risk of slight injury or damages of devices when dealt with incorrectly.
	Mark for prohibition This mark denotes prohibition of specified conducts. Description of the prohibition is displayed near the mark.

Precautions on equipment

	Be careful of high voltage inside High voltage, which may risk you life, is used. This high voltage may remain in the circuit even after the power is switched off. To prevent contact with the high voltage circuits accidentally, a protective cover or the label with this mark is provided on the high voltage circuit. When the inside is to be checked, ensure to switch off the power and to discharge the residual voltage for safety. An engineer authorized by Koden shall carry out the inspection and maintenance works.
 Warning	Power off in the boat An accidental power-on during works may result in worker's electrification. To prevent such accident in advance, ensure that power in the boat and on the equipment are switched off. Furthermore, it is safer to hang a caution tag saying "Under work" near the power switch of equipment.
 Warning	Be careful of dust Inhaled dust may cause respiratory affection. At the time of cleaning the inside of equipment, be careful not to inhale dust. Wearing a safety mask is recommended.
 Caution	Caution on location of installment The equipment shall not be installed at locations which are excessively damp and suffers from water drops. Otherwise, dew condensation may occur inside the display screen, and corrosion may occur inside the unit box.

 <p>Caution</p>	<p>Measures against static electricity Static electricity may be generated from the carpet on the floor in the cabin or clothes made of synthetic fiber, and it may destroy the electronic components on circuit boards. The circuit boards shall be handled with appropriate measures against static electricity.</p>
---	--

Precautions on handling

 <p>Warning</p>	<p>No disassembly or modification of this equipment is allowed. It may lead to failure, firing, smoking or electric shock. In case of failure, please contact Koden's dealers or Koden.</p>
 <p>Warning</p>	<p>In case of smoking or firing, switch off the power in the boat and of this equipment. It may lead to firing, electric shock or damages.</p>
	<p>Be careful of residual high voltage High voltage may remain in capacitors for several minutes after switching off the power. Before inspection of the inside, please wait at least 5 minutes after switching off or discharge the residual electricity in an appropriate manner. Then, start the work.</p>
 <p>Caution</p>	<p>The information displayed on this equipment is not intended to use for your navigation. For your navigation, be sure to see the specified materials.</p>
 <p>Caution</p>	<p>Use properly rated fuse. If incorrect fuse is used, it may cause fire, smoke or damage.</p>

Contents

Revision History.....	i
Important Notice	ii
For your Safe Operation.....	iii
Symbol used in this Instruction Manual	iii
Precaution on equipment	iii
Precaution on handling	iv
Contents	v
Introduction.....	vi
System configuration.....	vii
Configuration of equipment	viii
Chapter 1 Specification	
1.1 Specifications	1-1
1.2 Serial data	1-1
1.3 Power supply specifications.....	1-1
1.4 Compass safe distance.....	1-1
1.5 Operating environment	1-1
1.6 External dimensions and weight	1-2
Chapter 2 Installation	
2.1 Installation precautions	2-1
2.2 Unpacking and inspection of the goods.....	2-1
2.3 Installation site	2-1
2.3 Installation method.....	2-3
Chapter 3 Technical References	
3.1 Serial input/output data.....	3-1
3.1.1 Input data	3-1
3.1.1.1 Various settings.....	3-1
3.1.2 Output data	3-1
3.1.2.1 Format.....	3-1
3.1.2.2 Data form	3-1
3.1.2.3 Data configuration	3-1
3.1.2.4 Output sentence.....	3-2
3.2 Cable connections and connector pin-outs.....	3-4
3.3 Input/Output circuits	3-4
3.3.1 Input circuit	3-4
3.3.2 Output circuit	3-4

Introduction

The GPS-20A MkII is a high performance GPS receiver module containing 24-channel parallel receiver sensor, which is ready for the SBAS^{*1} / MICHIBIKI (Quasi-Zenith Satellite System)^{*2} service. By simply connecting a power supply to the GPS-20A MkII, highly accurate position data can be quickly supplied to a Plotter or the ship's navigation devices.

GPS (Global Positioning System) is a position measuring system that uses 4 satellites for each of 6 orbits (3 spare), with durations of 11 hours 58 minutes, orbiting approximately 20,000km above the earth.

GPS is based on the principle of calculating the distance of 3 or more satellites from the user and deriving the user's position. The intersect point of the orbital trajectories becomes the current measured position (latitude, longitude, altitude.)



GPS uses the (World Geodetic System) coordinate system. On previous global maps, each zone used a different coordinate system. However, by using the WGS system where all zones are unified to one coordinate system, the latitude and longitude are used in positioning. Therefore, when using a map that uses a different coordinate system, the map lat/lon may be different to the lat/lon displayed on the navigation unit.

The GPS-20A MkII conforms to the General Requirements of Maritime Navigation and Radio communication Equipment and Systems, IEC 60945 (Ed.4).

^{*1}SBAS is a robust system designed to greatly improve the accuracy of GPS positioning using geo-stationary satellites currently being produced in the US, Europe and Japan. There are 3 types of systems being produced, WAAS in the US, EGNOS in Europe and MSAS in Japan. Because position correction data is transmitted from geo-stationary satellites, it is possible to receive position correction data anywhere in the world.

^{*2}MICHIBIKI (Quasi-Zenith Satellite System) is a Japanese satellite positioning system composed mainly of satellites with quasi - zenith orbit. Four satellites take non-symmetrical figure-of-moons trajectory up and down, so that one satellite in the country will always be arranged in the zenith direction, complementing GPS positioning. Moreover, positioning accuracy can be improved by receiving sub meter-class reinforcement signals broadcast from the quasi-zenith satellite

System Configuration

GPS receiver module
GPS-20A MkII

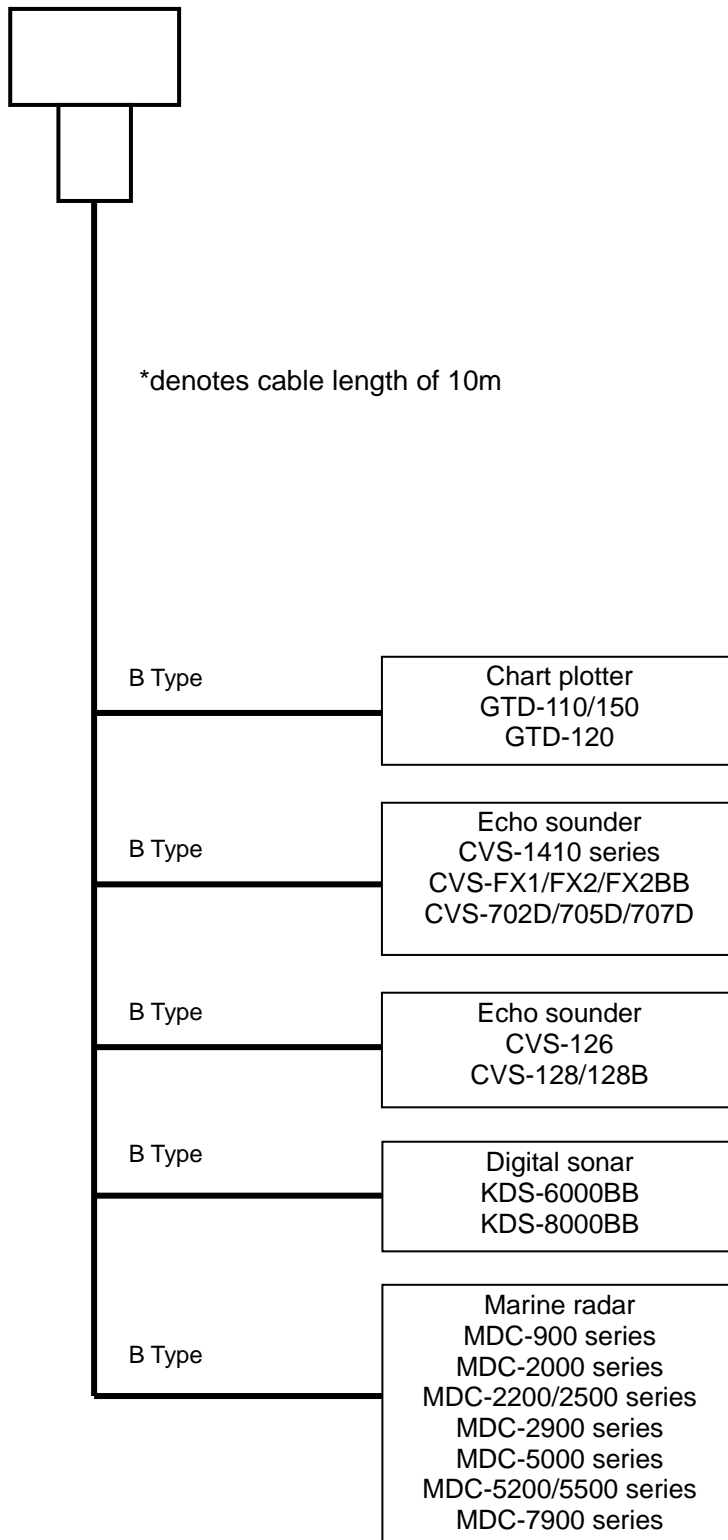

Configuration of Equipment

Standard Equipment Configuration List

No.	Item	Type name	Remarks	Weight	Q'ty
1	GPS Receiver Module	GPS-20A MkII	Type B Cable: CW-563-3-10M With 6P connector (BD-06BFFA-LL6001) fitted	250 g (Cable not included)	1
2	Installation Manual	GPS-20A MkII.IM.E	English		1

Option List

No.	Item	Type name	Remarks
1	Connector	BD-06BFFA-LL6001	6 pin, waterproof type
2	Cable extension kit	KBG-3_CABLE-KIT	For 15m extension

Chapter 1 Specification

1.1 Specifications

Receive frequency		1575.42MHz±1MHz
Receive channels		24 parallel channels
Sensitivity		-168dBm
Positioning accuracy	Position	GPS: 10m (2drms, SA=OFF, PDOP: 3 or less) SBAS: 7m (2drms, SA=OFF, PDOP: 3 or less)
	Velocity	1m/sec (rms, SA=OFF, PDOP: 3 or less)
Tracking	Velocity	972km/h max
	Accel.	Below 1 G
Position update interval		1sec.
Position fixing time	Cold start	35secs (standard value)
Differential positioning	RX input	SBAS (WAAS, MSAS, EGNOS) QZSS (L1S)

1.2 Serial data

(1) Format: NMEA-0183 Ver. 2.3

(2) Input data

Parameter settings: KODEN private command, 4800bps

Refer to chapter 3 for details.

(3) Output data

Sentence: GGA, GLL, GSA, RMC, VTG, ZDA

1.3 Power supply specifications

Input voltage: 10.8 to 31.2 VDC

Power consumption: 0.6W max.

1.4 Compass safe distance

Standard: 0.8m

Steering: 0.4m

1.5 Operating environment

The main operating environment conditions are stated below.

(1) Temperature, humidity

Operating temperature: -25 to +55 °C

Storage temperature: -30 to +70 °C

Maximum humidity: 93 ± 3% (at +40 °C)

(2) Vibration

The following levels of vibration can be tolerated with no adverse affect on performance.

Ranging from 2~5 Hz to 13.2 Hz, oscillation amount $\pm 1\text{mm} \pm 10\%$ (Maximum rate of 7m/s^2 at 13.2 Hz)

Maximum acceleration of 7m/s^2 between 13.2 Hz and 60 Hz.

(3) Water resistance

IPX6 standard (IEC 60945)

Water resistant type (JISF8001)

1.6 External dimensions and weight

Dimensional diagram: Refer to the diagram below

Weight: 250g (0.55 lb) (Except cable)

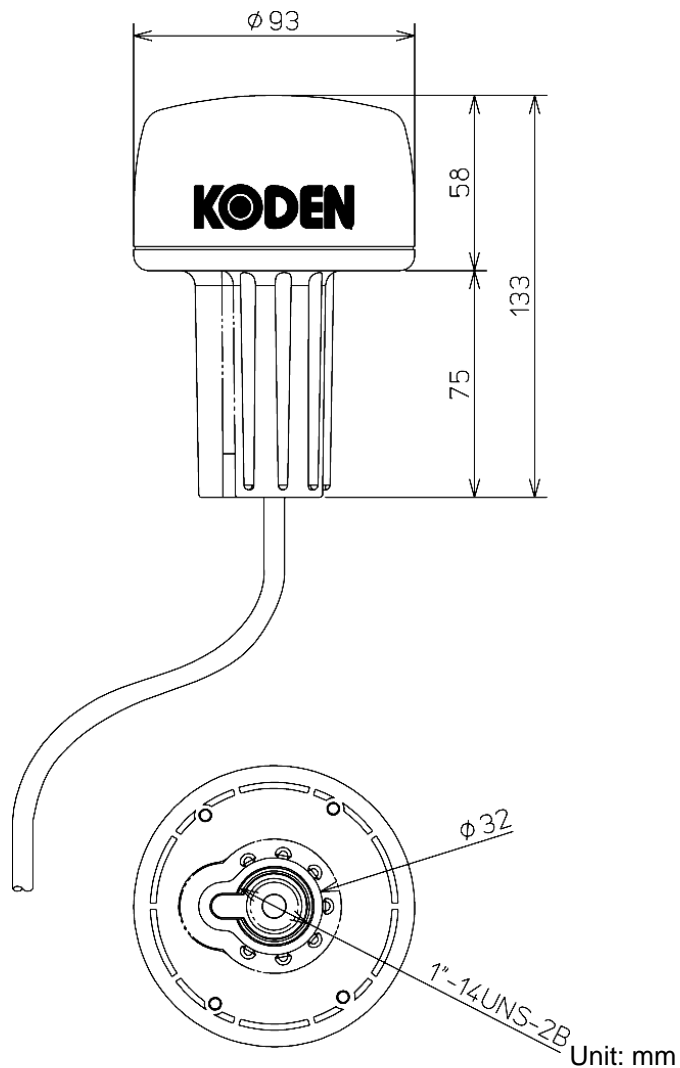

Figure 1.1 GPS-20A MkII external dimensions

Chapter 2 Installation

2.1 Installation precautions

The installation of the GPS receiver module should only be carried out by qualified technicians. Installing the GPS receiver module comprises the following actions.

- (1) Unpacking and inspecting the components.
- (2) Checking the power supply voltage and current capacity is rated for the GPS receiver module.
- (3) Determining the installation site.
- (4) Cable laying.
- (5) Installing the GPS receiver module.

2.2 Unpacking and inspection of the goods

Unpack the contents and check each component against the component delivery list. If the contents differ from that which is on the list, or there are damaged components, contact the shipping agent or the nearest KODEN dealer.

2.3 Installation site

Be sure to install the GPS receiver module in the highest possible location on the ship for optimum reception of the satellite signal.

Any obstructions in the vicinity of the antenna could result in the loss of the satellite signal reception, positioning time degradation or a reduction in the position accuracy.

- (1) Keep at least 0.5m away from metallic objects.
- (2) Keep at least 4m away from MF/HF L type transmission antennas and VHF or HF whip antennas.
- (3) Keep at least 1.5m away vertically, from MF/HF L type transmission antennas.
- (4) Keep at least 1m away from receive antennas.
- (5) Install away from the ship's radar beam (straight beam angle: 30 – 40 degrees).
- (6) Keep at least 1m away from the ship's Radar antenna.
- (7) Keep at least 5m away from the INMARSAT antenna.
- (8) Keep at least 3m away from loop antennas.
- (9) Keep at least 2m away from the ship's engine.
- (10) Display devices such as cathode ray tubes and LCDs can sometimes interfere with the reception of beacon signals. Keep at least 1m away from display devices such as Plotters, Radars and Sounders.

Refer to Table 1 for the recommended safe installation distances from masts and struts of the ship's super-structure.

Table 1 Minimum distances between support struts

Object	Diameter	Minimum distance
Support strut	10cm	1.5m
Support strut	30cm	3.0m

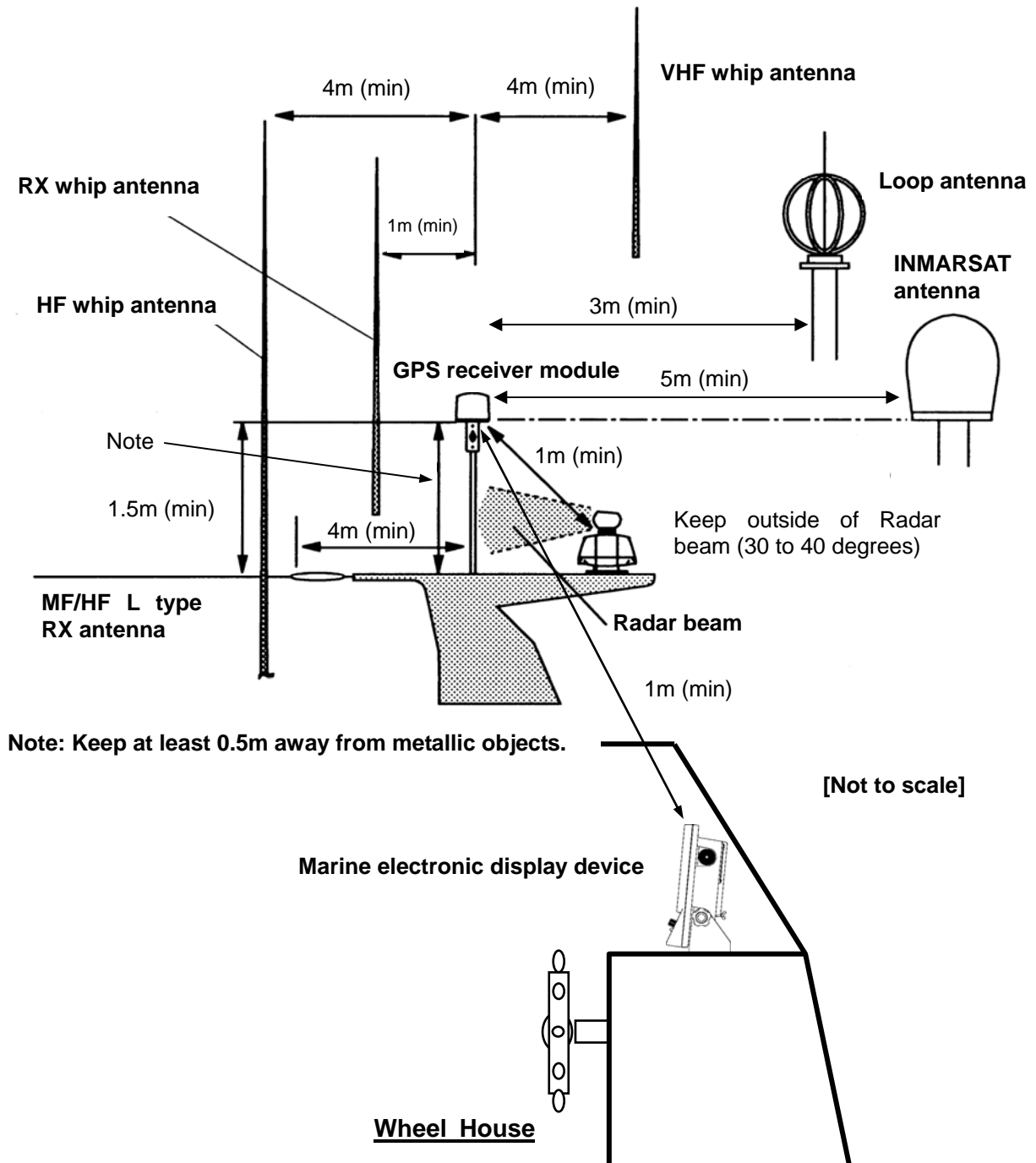

Fig. 2.1 Recommended installation site for the GPS receiver module

2.4 Installation method

The following examples show typical installation methods.

Installation example 1: The pole used has no screw thread tooled. Fix the GPS20A MkII to the pole using the hose band and tighten firmly.

Installation example 2 and 3: The pole used is screw threaded (1-14UNS-2A). In a case when the connecting cable cannot be put through inside the pole, fix the cable at an interval of 30 to 40 cm to the pole using an appropriate tie (See NOTE).

NOTE: A plastic tie is subject to deterioration caused by ultraviolet ray, etc. Use a stainless tie or equivalent, having stable characteristic against the harsh marine environment.

Installation example 1

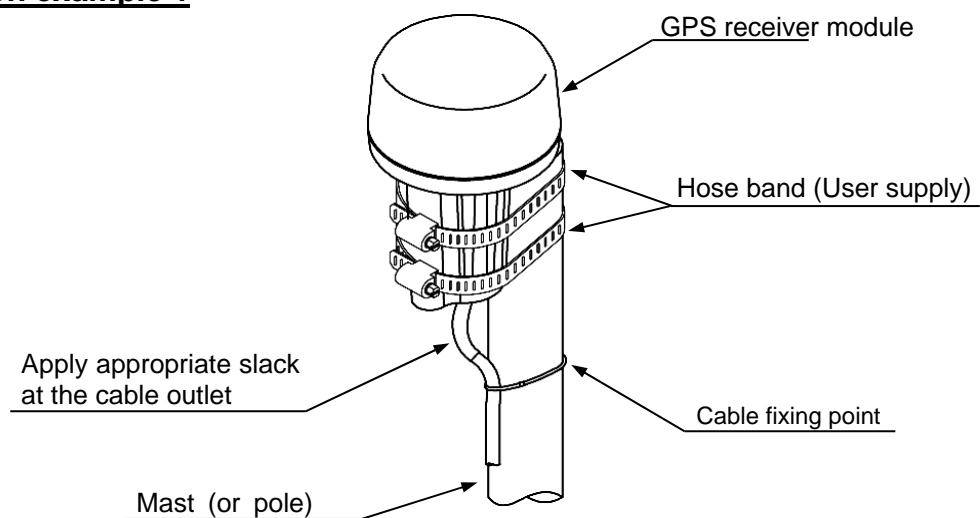

Installation example 2

Keep the cable away from the pole as possible to avoid scratching by the exposed thread.

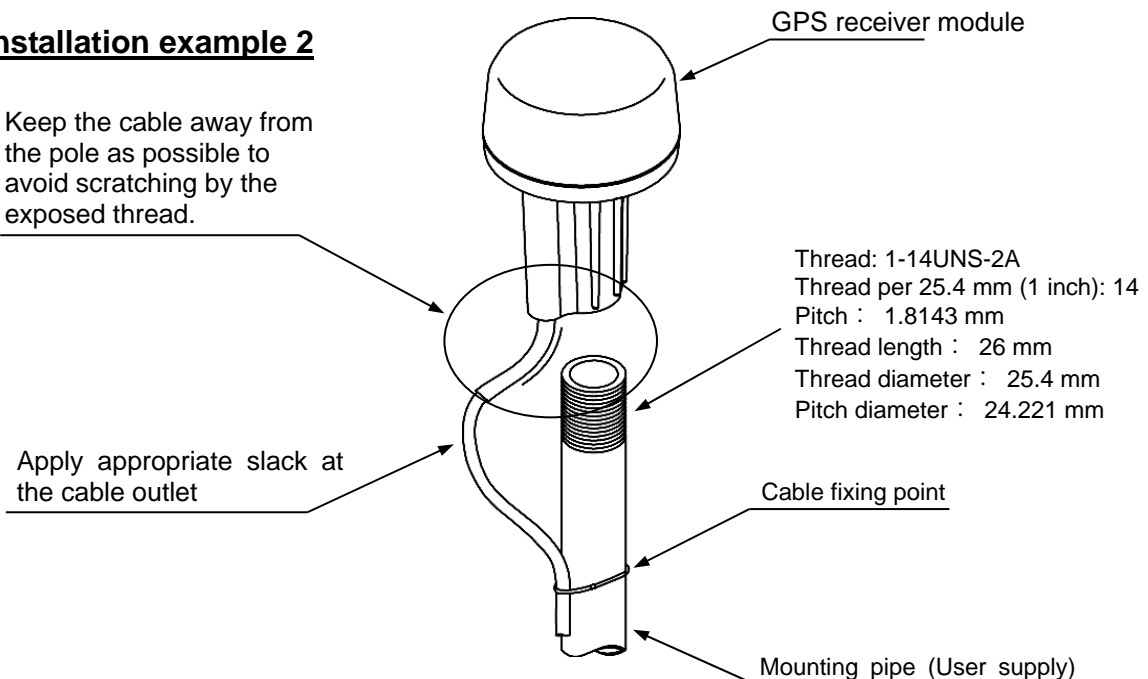

Installation example 3

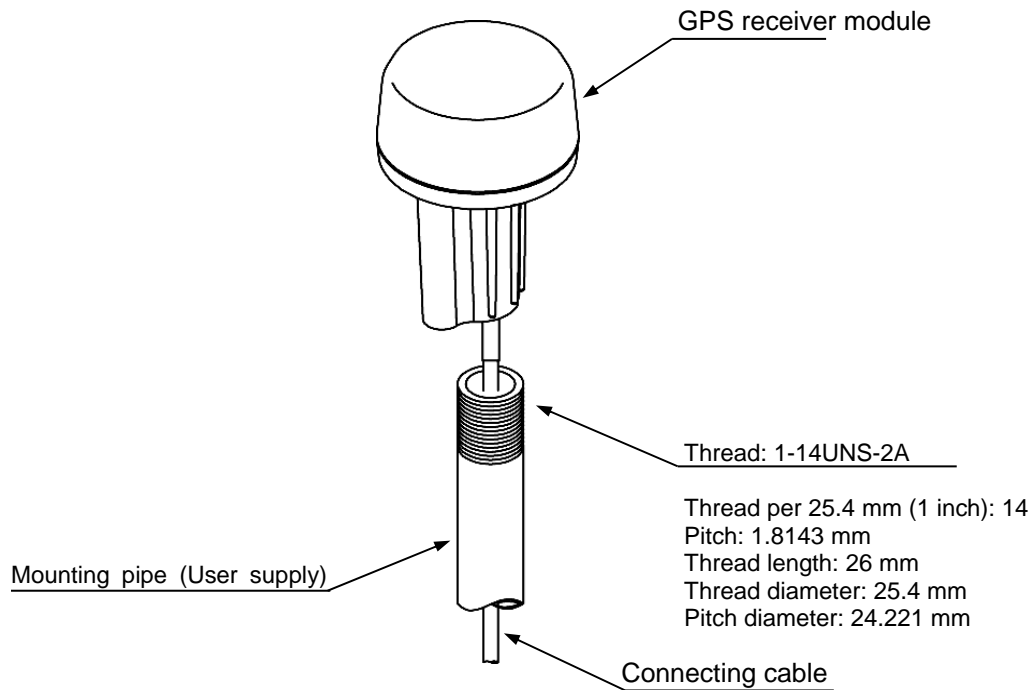

Installation precautions

- (1) Adhesive plastic sealant or silicone for plastic is recommended for fixing screws.



Caution: Use of other solvent or anaerobic based-bond may cause cracking of the chassis.

- (2) Stroke of screw insertion should be up to 25mm.



Caution: Overtightening of the screw may cause cracking of the chassis.

Chapter 3 Technical References

3.1 Serial input/output data

3.1.1 Input data

3.1.1.1 Various settings

X 0000 <CR><LF>
 1 2 3

1: Header (HEX)
 2: Setting value (ASCII code, integer)
 3: End code

Baud rate: 4800bps

Item to set	Header (hex)	Setting range	Initial setting
Geodetic Datum	15	00: WGS-84, 02: TOKYO	00: WGS-84
SBAS setting	18	0:OFF, 2:ON (SBAS), 3:ON (L1S)	2:ON(SBAS)
Initialization	1E1E1E	_____	_____

3.1.2 Output data

3.1.2.1 Format

NMEA-0183 Ver.2.3

3.1.2.2 Data form

One byte of data has the following form.

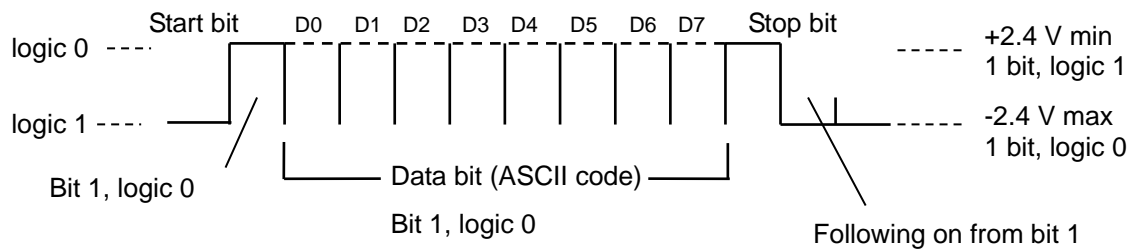

3.1.2.3 Data configuration

Signal speed	Output voltage level	Output current	Output sentence	Update rate
4800 Baud	RS-422	20mA max	GGA+GLL+GSA+RMC+VTG+ZDA	1sec

3.1.2.4 Output sentence

Note: *hh: Checksum <CR>: Carriage return <LF>: Line feed

<p>GPGGA</p>	<p>GPS Positioning Data</p> <p>\$ GP GGA, hhmmss, xxxx.xxxx, N/S, xxxxx.xxxx, E/W, x, xx, xxx.x, 0/- xxxx, M, 0/-xxx, M, , *hh<CR><LF></p>
<p>GPGLL</p>	<p>Geographic position (latitude/longitude)</p> <p>\$ GP GLL, xxxx.xx, N/S, xxxxx.xx, E/W, hhmmss, a, a*hh <CR><LF></p>
<p>GPGSA</p>	<p>GPS DOP and active satellites</p> <p>\$ GP GSA, A, x, xx, xx, xx, xx, xx, xx, xx, xx, xx, xx, xx, x.x, x.x, x.x *hh <CR><LF></p>
<p>GPRMC</p>	<p>Recommended minimum specific GPS data</p> <p>\$ GP RMC, hhmmss, A, xxxx.xxx, N/S, xxxx.xxx, E/W, xxx.x, xxx.x, xxxxxxx, , , *hh <CR><LF></p>

<p>GPVTG</p>	<p>Course over ground and ground speed</p> <p>\$ GP VTG, xxx.x, T, , , xxx.x, N, xxx.x, K, a*hh <CR><LF></p>
<p>GPZDA</p>	<p>Time and Date</p> <p>\$ GP ZDA, hhmmss, xx, xx, xxxx, , *hh <CR><LF></p>

3.2 Cable connections and connector pin-outs

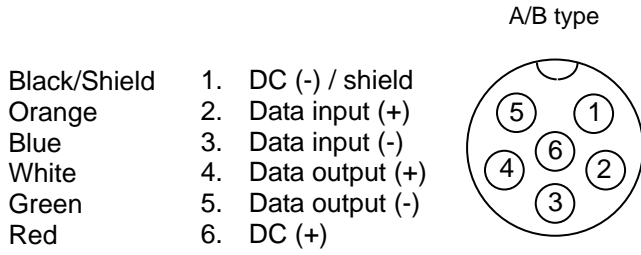

3.3 Input/Output circuits

3.3.1 Input circuit

Input load: 470 ohm

Device: Photo-coupler TLP2362 (Toshiba)

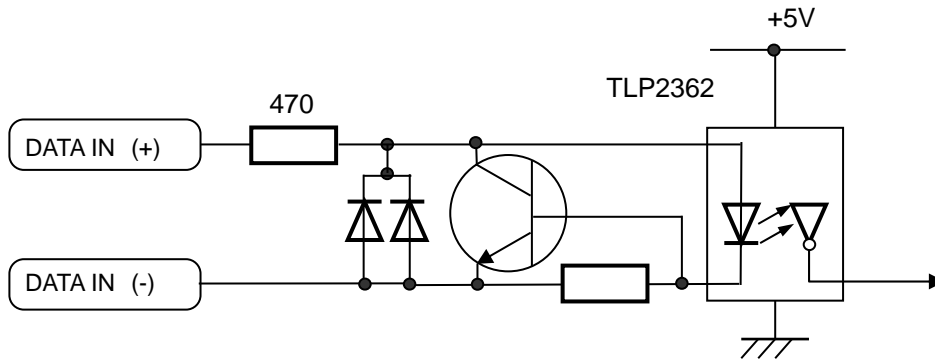

3.3.2 Output circuit

Driver: AM26C31I (Texas instruments)

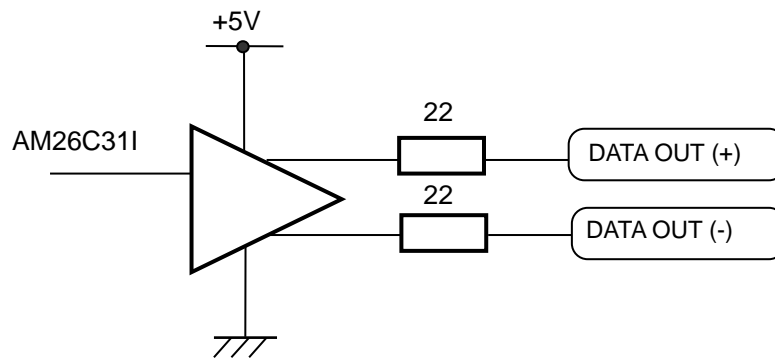



Koden Electronics Co., Ltd.

Tamagawa Office:

2-13-24 Tamagawa, Ota-ku, Tokyo, 146-0095 Japan

Tel: +81-3-3756-6501 Fax: +81-3-3756-6509

Uenohara Office:

5278 Uenohara, Uenohara-shi, Yamanashi, 409-0112 Japan

Tel: +81-554-20-5860 Fax: +81-554-20-5875

www.koden-electronics.co.jp