

## SPECIFICATIONS

### Recorder Unit

Measuring system	Ultrasonic echo sensing system			
Recording system	DM-602	Direct recording in two directions (X-X' or Y-Y')		
	DM-604	Direct recording in four directions (X-X' and Y-Y')		
Recording paper	Electrosensitive recording paper 250 mm x 20 m (DMP-250)			
Measuring range	0.5 m	1.0 m	2.0 m	4.0 m
(radius)	Shift 0%	0 to 0.5 m	0 to 1.0 m	0 to 2.0 m
	50%	0.25 to 0.75 m	0.5 to 1.5 m	1.0 to 3.0 m
	100%	0.5 to 1.0 m	1.0 to 2.0 m	2.0 to 4.0 m
Paper feed	Constant speed 7.5 mm/min, 15 mm/min, 30 mm/min and 60 mm/min			
rate	Synchronized 1/40	25 mm/m of sensor up/down movement		
	with the depth 1/50	20 mm/m of sensor up/down movement		
	1/100	10 mm/m of sensor up/down movement		
	1/200	5 mm/m of sensor up/down movement		
Measuring accuracy	±2% at full scale			
Depth mark	A depth mark is printed every 1 m and depth is automatically printed numerically every 5 m			
PC display and storage	Serial data output provided (RS 232C cable: option)			
Power supply protection circuit	Equipped with two built-in non-fuse breakers (2 A and 8 A), a leakage breaker (20 A) and an overvoltage protection circuit			
Power supply	100 VAC, 50/60 Hz	110 VAC, 50/60 Hz	220 VAC, 50/60 Hz	440 VAC, 50/60 Hz
Power consumption	500 VA (At 100 VAC)	700 VA (At 110 VAC)	700 VA (At 220 VAC)	700 VA (At 440 VAC)
Operating temperature	-10°C to +50°C (14°F to 122°F)			

### Winch Unit

Up/down speed	0 to 20 m / min
Up/down movement distance	100 m maximum
Bottom and casing sensing system	Automatic sensing by limit switch
Operating temperature	-10°C to +50°C (14°F to 122°F)

### Standard Configuration

Recorder unit	DMR-602 (DM-602)	Contained in an aluminum box	47 kg
	DMR-604 (DM-604)	Contained in an aluminum box	47 kg
Power supply (Built into Recorder unit)	DMT-000	For 100 VAC, contained in an aluminum box	10 kg
	DMT-001	For 110 VAC, contained in an aluminum box	10 kg
	DMT-002	For 220 VAC, contained in an aluminum box	10 kg
	DMT-003	For 440 VAC, contained in an aluminum box	12 kg
Winch unit	DMW-001A (DM-602)	With a sensor unit and cable	121 kg
	DMW-002A (DM604)	With a sensor unit and cable	121 kg
Connecting cable	CW-558	With 15-pin connectors	10 m
AC power cable	CW-71	With 3-pin connectors	10 m
Spare parts kit		Included in Recorder unit	1 set
Operation manual	93170152	Contained in Recorder unit	1
Brief operation card	for DM-602	Contained in Recorder unit	1
	for DM-604	Contained in Recorder unit	1

### Spare Parts List

Recording paper	DMP-250	250 x 20 mm (A3-560)	2
Recording stylus	DMS-001	Included in a vinyl bag	2
Current feed stylus	DMS-002	Included in a vinyl bag	2

### Optional Item

RS 232C output port	CW-384	Output connector: D-Sub 25 pin	
---------------------	--------	--------------------------------	--

## DIMENSIONS AND WEIGHT

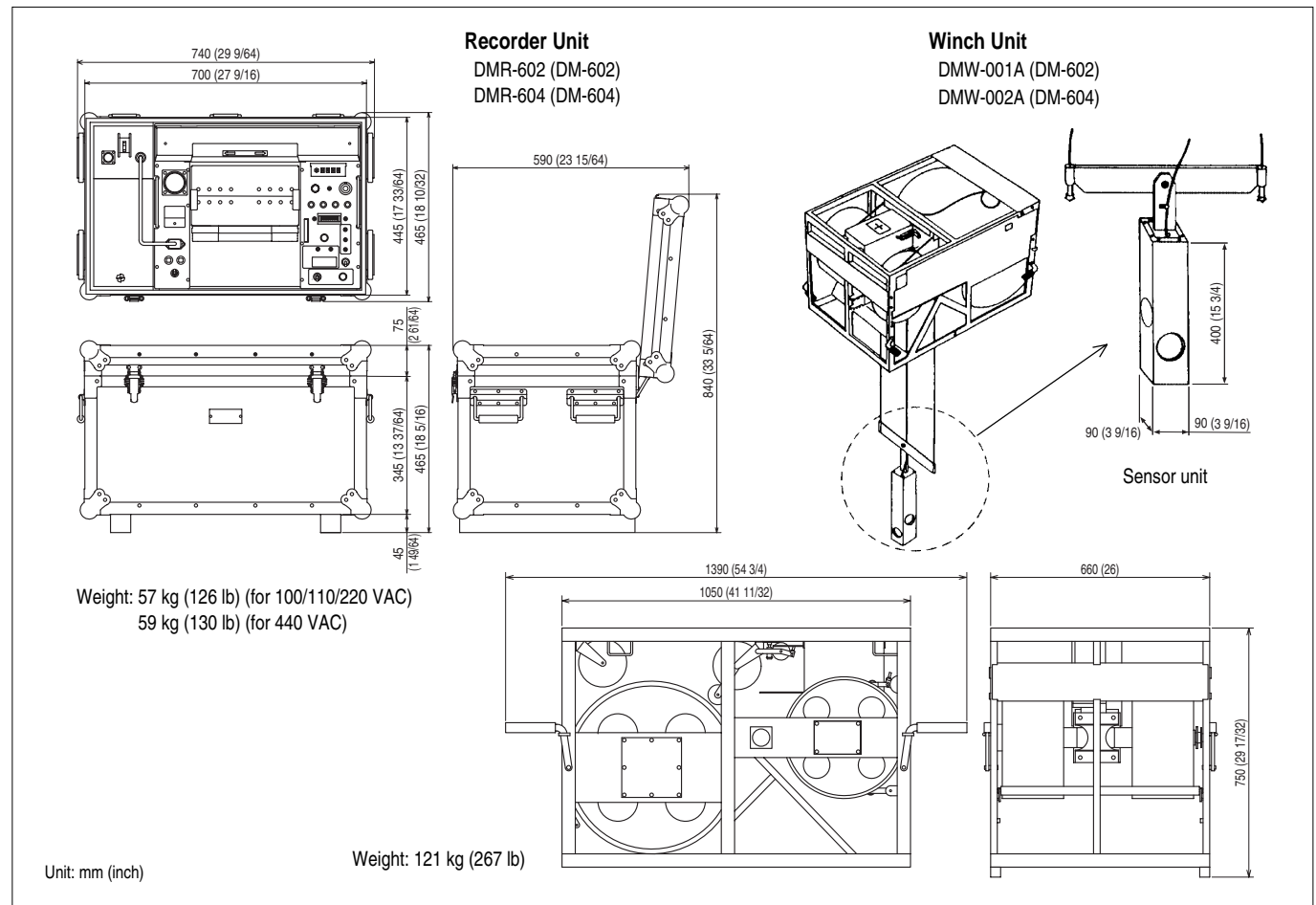

# KODEN

## Ultrasonic Drilling Monitor

# DM-602/604

*Koden promotes intelligent foundation work.*



- Deeper excavation measurement in high accuracy
- Clear recording even in slurry contaminated with dirt and sand
- High quality excavation work reducing time and cost

**KODEN** Koden Electronics Co., Ltd.

Tamagawa Office:  
2-13-24 Tamagawa, Ota-ku, Tokyo, 146-0095 Japan  
Tel: +81-3-3756-6501 Fax: +81-3-3756-6509  
Uenohara Office:  
5278 Uenohara, Uenohara-shi, Yamanashi, 409-0112 Japan  
Tel: +81-554-20-5860 Fax: +81-554-20-5875

overseas@koden-electronics.co.jp

www.koden-electronics.co.jp



**Safety precaution**

To ensure proper and safe use of the equipment, please carefully read and follow the instructions in the Operation Manual.

For details, please contact:

www.koden-electronics.co.jp

# The DM-602/604 helps improve the quality of a drilled hole and reduces working time and cost!

## General

Recent progress and development in foundation engineering has resulted in great strides in excavation techniques. By using artificial slurry of high density and specific gravity, deeper excavation has been made possible. The DM-602/604 series Drilling Monitor system has been developed in compliance with the user's needs arisen from the recent construction environment to accurately measure and record the shape of a drilled hole of greater depth. It can be easily positioned and set up for measurement to provide quick and accurate recordings of excavations. The DM-602/604 series Drilling Monitor provides the following advantages.

- Helps improve the quality of a drilled hole and reduces working time and cost.
- Provides on site records of the perpendicularity of drilled holes and the shape of cross sections in high accuracy.
- Provides numerical measurement data that can be easily imported into various Windows applications (Excel, Word, PowerPoint, etc.) for work reports, etc. (Option)

## Features

- The DM-602/604 supplies clear records of a drilled hole even in slurry, heavily contaminated with dirt and sand.
- The DM-602/604 supplies clear and precise records thanks to its unique signal processing technique that discriminates wall echoes from the noise.
- The DM-602/604 has the facility to cancel the oscillation line echo that often prevents very close echo recordings.
- The sensor device is automatically controlled to stop at the casing and at the bottom of the hole. An emergency return function is also included.
- Depth range mark, depth mark, drilled hole mark, date, time, etc. can be printed on the recording paper.
- Limit switches are provided to avoid possible wire breakage or entanglement of the wire and cable.
- The recorded result can be output to an external PC via a built-in RS 232C output port. (Option)
- A non-fuse circuit breaker is used for circuit protection, eliminating the need for cumbersome fuse replacement at the construction site.



The winch unit and recorder unit on site



Recording the echo of a drilled hole

## Main controls/switches

(Photograph shown is DM-604 operation panel)

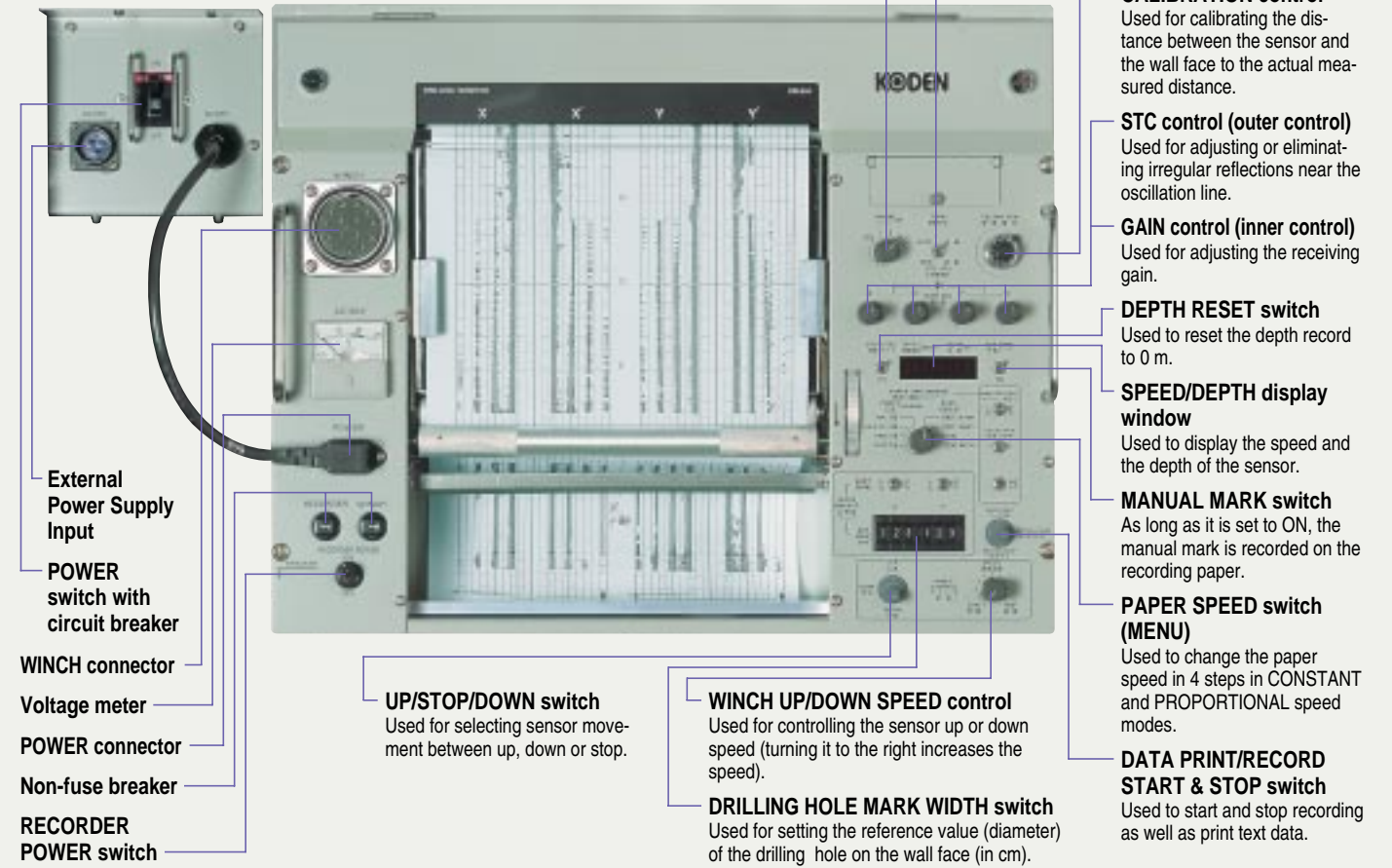

## Recording Examples

